

4. 驱动桥/Drive Axles

序号/ No.	名 称 / Designation		页 码 /Page No.
4,01	双后驱动桥总成/Rear Tandem Drive Axles	-----	1
4,02	中桥驱动装置/1st Rear Axle Drive	-----	2
4,03	后桥驱动装置/Rear Axle Drive	-----	8
4,04	中桥桥壳/1st Rear Axle Housing	-----	10
4,05	后桥桥壳/ Rear Axle Housing	-----	12
4,06	三段式铸造中桥轮毂及制动器/Hub and Brake of 1st Driving Axle	-----	14

4.01 双后驱动桥总成/Rear Tandem Drive Axles Ass.

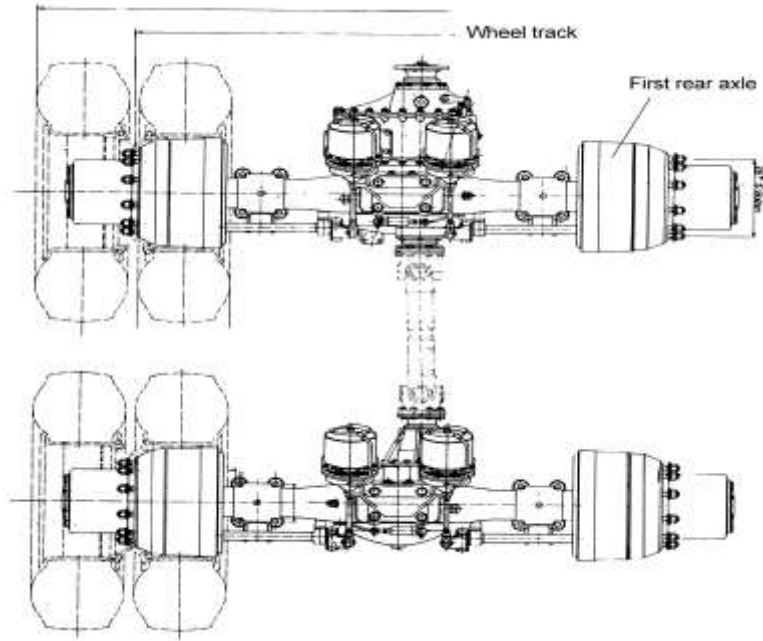

4.01 双后驱动桥总成/Rear Tandem Drive Axles Ass.

序号 No.	零部件图号 Part No.	名称	Part Name	数量 Qty	备注 Remark
0	AH71131400971	HC16双桥	Rear tandem drive axles ass	1	
0,1	AH71131541971	三段式铸造中桥(QT) (4.8, XS Φ180, 185)	1st rear axle ass.(i=4.8)	1	
0,2	AH71131551971	三段式铸造后桥(QT) (4.8, Φ165, 185)	Rear axle ass.(i=4.8)	1	

主要配置/Main Configurations

1		型号:HC16	Mode:HC16		
2		铸造桥壳	Casting axle housing		
3		主减速比4.8	Reduction ratio4.8		
4		输入法兰Φ180mm	Input flange Φ180mm		
5		轮距1850mm	Wheel track 1850mm		

4.02 中桥驱动装置/Drive of 1st Rear Axle

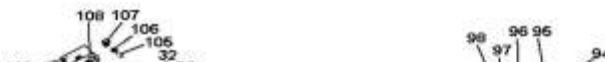

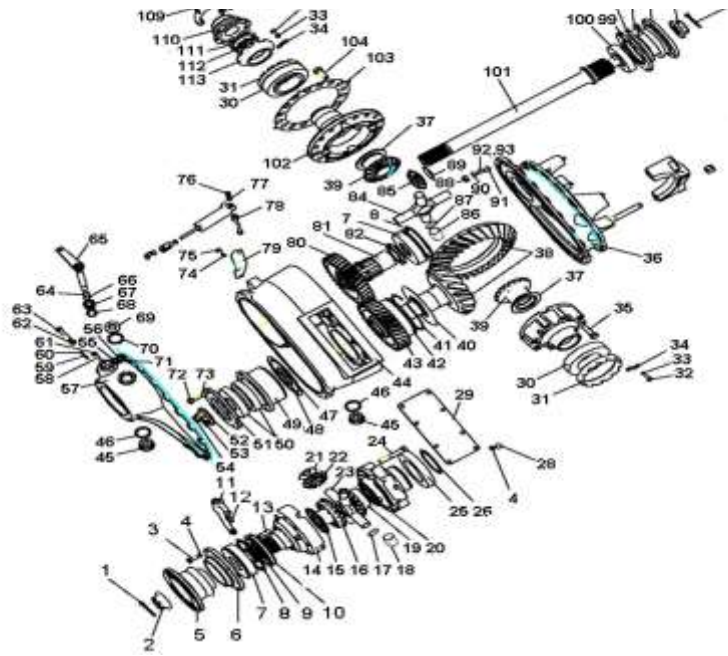

4.02 中桥驱动装置/Drive of 1st Rear Axle

序号	零部件图号	名称	Part Name	数量	备注
No.	Part No.			Qty	Remark
0	AZ9231320734	中桥中段 (i=4.8, XS φ 180)	1st rear axle drive ass.	1	
1	Q5005055	开口销	Split pin	1	
2	WG79000320013	凸缘螺母	Nut	1	
3	Q150B1025	六角头螺栓	Screw	8	
4	Q40310	弹簧垫圈	Spring washer	34	
5	AZ9231320014	XS φ 180凸缘总成	Flange ass.	1	
6	WG9014320175	端盖	Cover	1	
7	190003311543	有止动槽的向心球轴承	Bearing	2	
8	Q433130	轴用压扁钢丝挡圈	Snap ring	2	
9	WG9014320061	轴间差速器壳垫片	Shim	1	
10	WG288 320105	差速锁锁环	Ring	1	
11	WG9014320053	拨叉	Fork	1	
12	WG1800 320077	拨叉活动块	Block	2	
13	WG288 320106	差速锁销	Pin	10	
14	AZ9231320271	差速器壳	Diff. housing	1	
15	AZ9231320091~95	半轴齿轮(前)垫片	Shim	n	Depend on demand
16	WG9231320225	前半轴齿轮	Gear	1	
17	WG9231320222	衬套挡圈	Snap ring	4	

4.02 中桥驱动装置/Drive of 1st Rear Axle

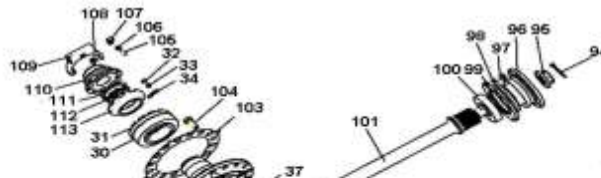

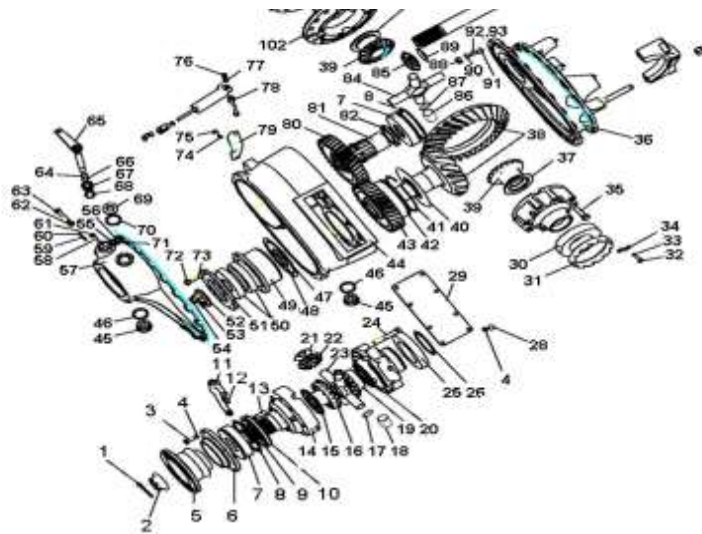

4.02 中桥驱动装置/Drive of 1st Rear Axle

序号	零部件图号	名称	Part Name	数量	备注
No.	Part No.			Qty	Remark
18	WG9231320221	衬套	Bush	4	
19	WG9231320226	后半轴齿轮	Gear	1	
20	AZ9231320096~10	半轴齿轮(后)垫片	Shim	n	Depend on demand
21	WG9231320224	行星齿轮垫片	Joint	4	
22	WG9231320227	行星齿轮	Gear	4	
23	AZ9231320223	十字轴	Spider	1	
24	Q151C1280TF2	六角头螺栓	Screw	12	
25	190003310239	带防尘盖深沟球轴承	Ball bearing	1	
26	190003933580	轴用弹性挡圈	Circlip	1	
28	Q150B1020Q	六角头螺栓	Screw	8	
29	WG9014320118	接油板总成	Plate	1	
30	190003326148	圆锥滚子轴承	Roller bearing	2	
31	WG3809320159	差速器轴承调整螺母	Nut	2	
32	Q150B0816	六角头螺栓	Screw	2	
33	Q40308	弹簧垫圈	Spring washer	2	
34	WG79000320027	止动片	Safety clip	2	
35	WG9231320169	六角头螺栓	Screw	8	
36	WG9014320120	主减速器壳(中桥)	Housing of rear driver	1	
37	AZ9231320154~15	调整垫片	Shim	n	Depend on demand
38	WG9114320251	锥齿轮副 28/17	Pinion and crown wheel	1	

4.02 中桥驱动装置/Drive of 1st Rear Axle

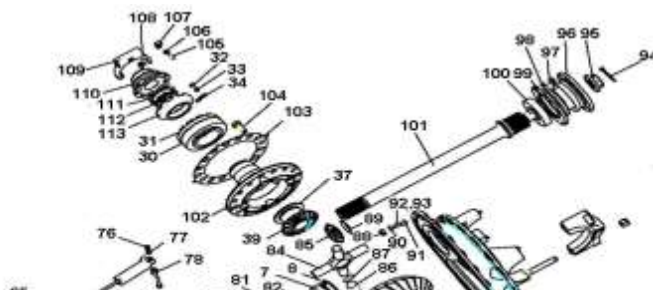

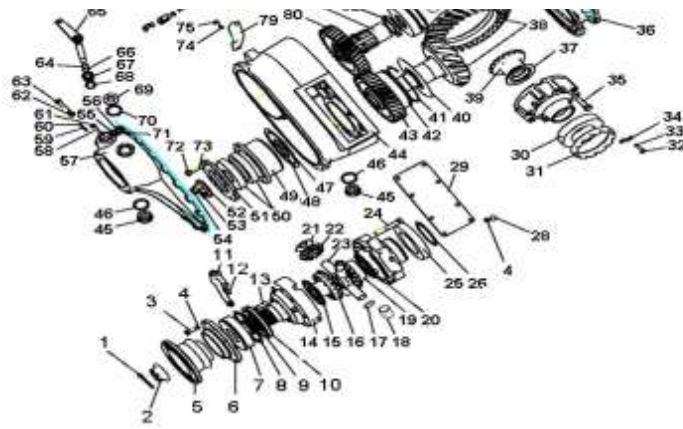

4.02 中桥驱动装置/Drive of 1st Rear Axle

序号	零部件图号	名称	Part Name	数量	备注
No.	Part No.			Qty	Remark
39	WG9231320151	半轴齿轮	Gear	2	
40	WG9014320174	挡油片	Plate	1	
41	WG9014320256	钢丝档圈	Snap ring	1	
42	WG9014320257	滚柱轴承	Roller bearing	1	
43	WG9014320208	从动圆柱齿轮z=26	Driven gear	1	
44	AZ9231320259	过桥箱	Housing	1	
45	1586 33 15	磁性螺塞总成	Plug	2	
46	Q72336	密封垫圈	Washer	3	
47	WG9014320131~1	调整垫片	Shim	n	Depend on demand
48	WG9014320140	隔圈	Ring	1	
49	WG9014320129	轴承座	Bearing seat	1	
50	190003326333	圆锥滚子轴承	Roller bearing	2	
51	WG9014320128	轴承外环压板	Plate	1	
52	WG780 320088	轴承压板	Plate	1	
53	WG9114320002	防松锁片	Locking sheet	1	
54	Q150B1430TF2	六角头螺栓	Screw	3	
55	Q340B10	六角螺母	Nut	18	
56	Q1201028F3	双头螺柱	Stud	18	
57	AZ9231320264	过桥箱盖	Housing cap	1	
58	190003902070	开槽长圆柱端紧定螺钉	Screw	1	

4.02 中桥驱动装置/Drive of 1st Rear Axle

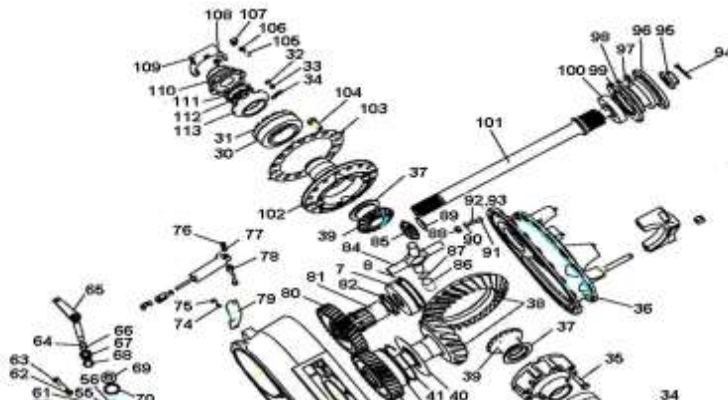

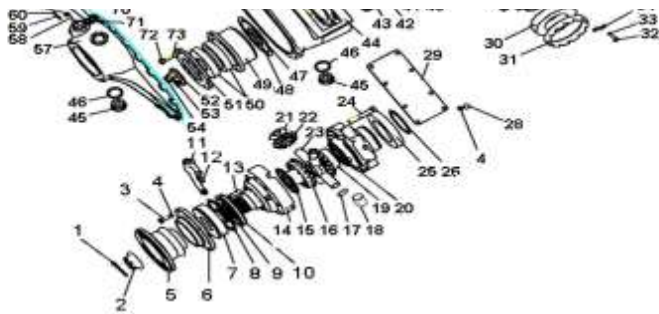

4.02 中桥驱动装置/Drive of 1st Rear Axle

序号	零部件图号	名称	Part Name	数量	备注
No.	Part No.			Qty	Remark
59	WG69000330008	销	Shaft	1	
60	Q43705	轴用钢丝挡圈	Circlip	1	
61	Q340B08	1型六角螺母	Nut	1	
62	Q340B10	六角螺母	Nut	1	
63	Q150B1050Q	六角头螺栓	Screw	1	
64	190003933072	轴用弹性挡圈	Circlip	1	
65	WG9014320076	差速锁摇臂总成	Rocker ass.	1	
66	WG288 730062	O型密封圈	O-ring	1	
67	WG2700 320037	衬套	Bush	1	
68	AZ9231320038	O形圈	O-ring	1	
69	WG81500010163	螺塞	Plug	1	
72	Q33210	六角锁紧螺母	Nut	8	
73	190003813543	双头螺栓	Stud	8	
74	Q40308	弹簧垫圈	Spring washer	2	
75	Q150B0818	六角头螺栓	Screw	2	
76	Q33208	六角锁紧螺母	Nut	1	
77	Q40108	平垫圈	Washer	1	
78	WG61000060072	隔套	Spacer	1	
79	AZ9231320262	托架总成	Bracket	1	
80	WG9014320209	主动圆柱齿轮z=31	Drive gear	1	

4.02 中桥驱动装置/Drive of 1st Rear Axle

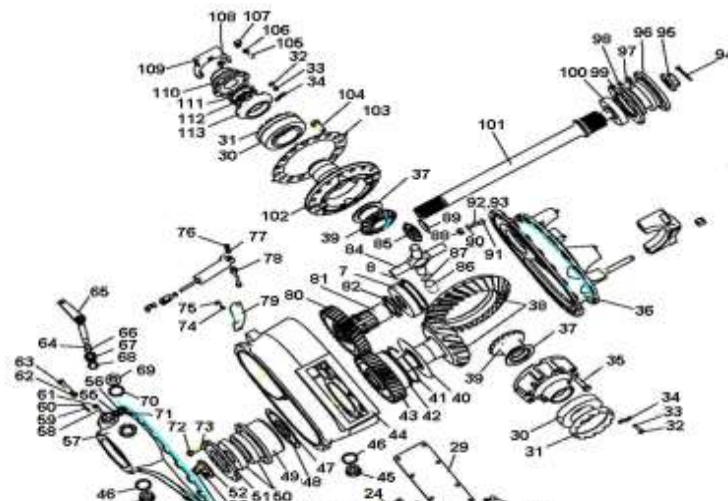

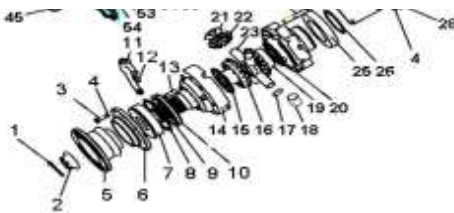

4.02 中桥驱动装置/Drive of 1st Rear Axle

序号 No.	零部件图号 Part No.	名称	Part Name	数量 Qty	备注 Remark
81	WG9014320135	空心轴	Hollow shaft	1	
82	WG9012250031	开槽圆螺母	Nut	1	
84	AZ9231320150	十字轴	Spider	1	
85	WG9231320152	行星齿轮	Gear	4	
86	WG9231320160	衬套挡圈	Ring	4	
87	WG9231320159	衬套	Bush	4	
88	Q340B12	I型六角头螺母	Nut	18	
89	WG9231320153	行星齿轮垫片	Sheet	4	
90	Q40312	弹簧垫圈	Spring washer	18	
91	Q5211016	圆柱销	Cylinder pin	4	
92	190003813628	双头螺柱	Stud	14	
93	Q1201225F3	双头螺栓	Stud	4	
94	Q5005055	开口销	Split pin	1	
95	WG79000320013	凸缘螺母	Nut	1	
96	WG9231320205	Φ165输出凸缘总成	Flange ass.	1	
97	Q150B1030	六角头螺栓	Screw	6	
98	Q40310	弹簧垫圈	Spring washer	6	
99	WG9231320141	轴承座	Bearing seat	1	
100	WG9231326212	双列圆锥滚子轴承	Roller bearing	1	
101	AZ9231320261	贯通轴	Driving shaft	1	

4.02 中桥驱动装置/Drive of 1st Rear Axle

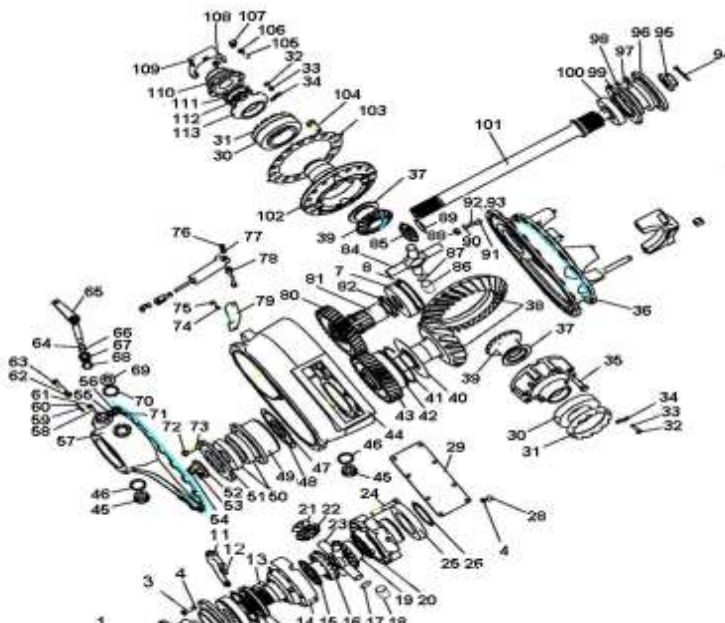

4.03 后桥驱动装置/Drive of 2nd Rear Axle

序号	零部件图号	名称	Part Name	数量	备注
No.	Part No.			Qty	Remark
0	AZ9231320721	后桥中段	Rear axle drive ass.	1	
1	Q5005055	开口销	Split pin	1	
2	WG79000320013	凸缘螺母	Nut	1	
3	WG9231320110	Φ165凸缘总成	Flange ass.	1	
4	WG9231320001	主减油封总成	Sealing ass.	1	
5	190003326236	圆锥滚子轴承	Roller bearing	1	
6	WG880 320002~15	调整垫片	Shim	1	
7	WG9012320131	轴承座	Bearing seat	1	
8	190003326546	圆锥滚子轴承	Roller bearing	1	
9	Q150B1230TF2	六角头螺栓	Screw	12	
10	WG9012320173~17	调整垫片	Shim	1	
11	WG9012320133	密封圈	Washer	1	
12	199012320098	主减速器壳	Rear driver housing	1	
13	WG79000320027	止动片	Retainer sheet	2	
14	Q40308	弹簧垫圈	Spring washer	2	
15	Q150B0816	六角头螺栓	Screw	2	
16	WG3809320158	锁止垫片	Locking shim	1	
17	WG3809320157	圆螺母	Nut	1	
18	WG3809320156	滑动啮合套	Sliding shifting sleeve	1	

4.03 后桥驱动装置/Drive of 2nd Rear Axle

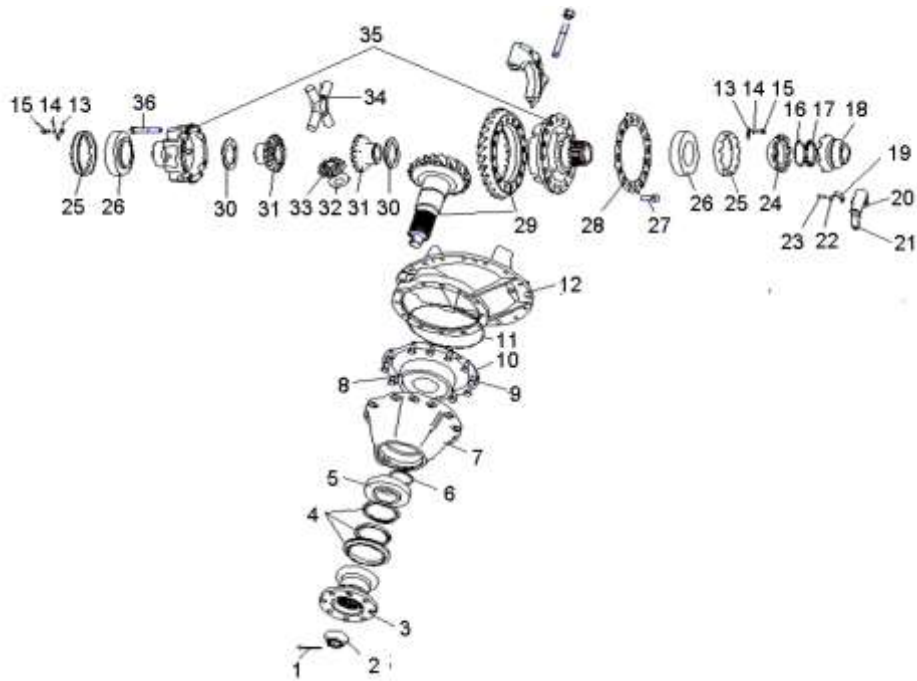

4.03 后桥驱动装置/Drive of 2nd Rear Axle

序号	零部件图号	名称	Part Name	数量	备注
----	-------	----	-----------	----	----

No.	Part No.	名称	Part Name	Qty	Remark
19	WG9231320023	弯板	Angle plate	1	
20	WG1800 320077	拨叉活动块	Block	2	
21	WG9012320014	拨叉	Fork	1	
22	Q340B08	1型六角螺母	Nut	1	
23	Q2800825	开槽锥端紧定螺钉	Screw	1	
24	WG3809320155	固定啮合套	Shifting dog	1	
25	WG3809320159	差速器轴承调整螺母	Nut	2	
26	190003326148	圆锥滚子轴承	Roller bearing	2	
27	Q151B1635TF2	六角头螺栓	Screw	16	
28	WG9114320003	锁片-从动锥齿轮螺栓	Screw	1	
29	WG9231320912	锥齿轮付 29/21	Pinion and crown wheel	1	
30	AZ9231320154~158	调整垫片	Adjusting shim	1	
31	WG9231320151	半轴齿轮	Gear	2	
32	WG9231320153	行星齿轮垫片	Gasket	4	
33	WG9231320152	行星齿轮	Gear	4	
34	AZ9231320150	十字轴	Spider	1	
35	AZ9231320274	差速器壳	Diff. housing	1	
36	WG9231320169	六角头螺栓	Screw	8	

4. 04 中桥桥壳/1st Rear Axle Housing

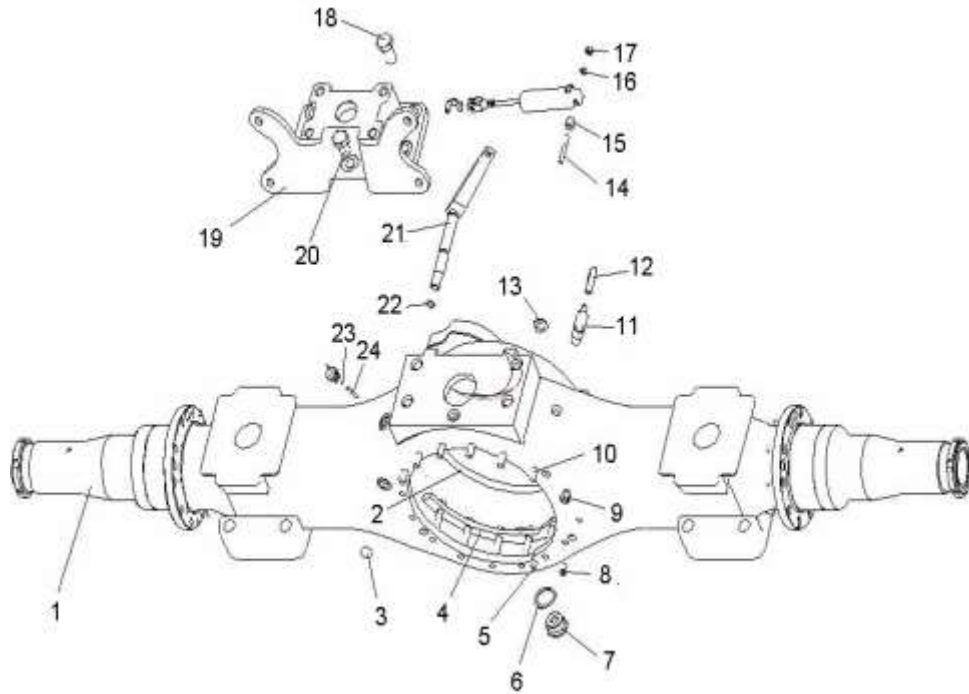

4. 04 中桥桥壳/1st Rear Axle Housing

序号	零部件图号	名称	Part Name	数量	备注
No.	Part No.			Qty	Remark
1	AZ9231330990	三段式铸造中桥壳总成	First rear axle housing	1	
1a	WG680340013	园螺母(右)	Ball nut	1	

1b	1680 340014	圆螺母(左)	Ball nut	1	
3	190003989290	碗形堵塞	Croe plug	1	
5	Q5211016	圆柱销	Cylinder Pin	1	
6	Q72336	密封垫圈	Gasket	1	
7	WG9231330015	磁性螺塞总成	Magnetic plug	1	
9	190003888457	自锁螺母	Nut	16	
10	190003810631	双头螺柱	Stud	4	
11	WG9231330105	通气塞	Breathing plug	1	
12	WG9231330106	橡胶软管	Hose	1	
13	190003962021	锥螺纹内六角螺塞	Screw	1	
14	Q1200850F3	双头螺柱	Stud	1	
15	WG61000060084	间隔衬套	Spacer bush	1	
16	Q40108	平垫圈	Washer	1	
17	Q33208	2型全金属六角锁紧螺母	Nut	1	
18	Q151B2045TF2	六角头螺栓	Screw	6	
19	WG9231340944	气室支架(中桥)	Bracket of chamber	1	
21	WG9014330126	操纵杆总成	Operating Lever ass.	1	
22	1680M 320015	O型垫圈	O-ring	1	

4. 04 中桥桥壳/1st Rear Axle Housing

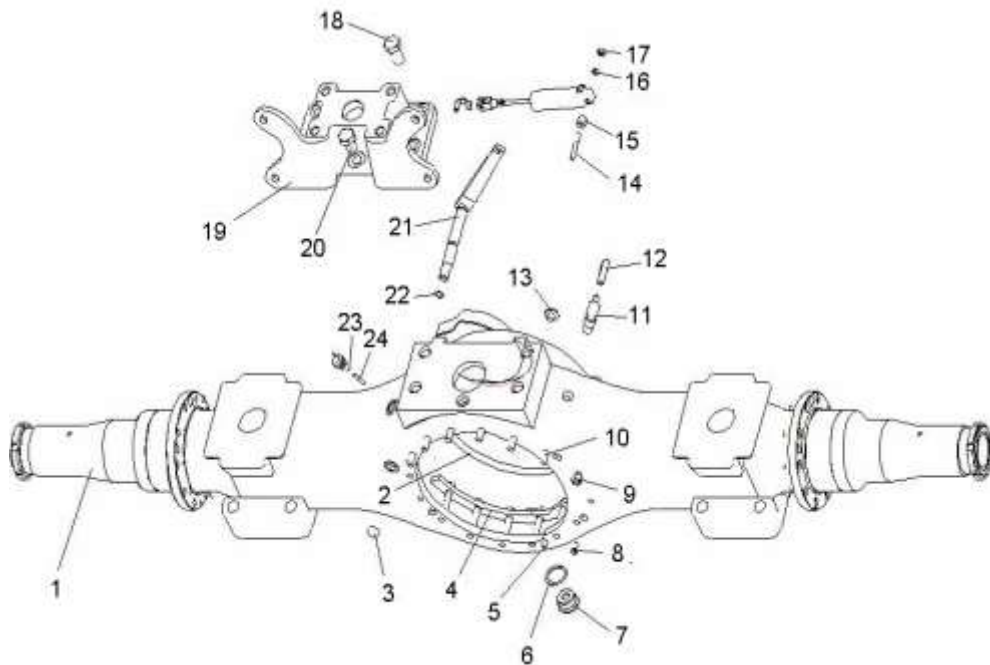

4. 04 中桥桥壳/1st Rear Axle Housing

序号 No.	零部件图号 Part No.	名称	Part Name	数量 Qty	备注 Remark
23	Q43705	轴用钢丝挡圈	Snap ring	1	
24	WG9112330016	销	Pin	1	
24a	WG9231330808	销	Pin	1	
24b	WG9231330809	销	Pin	1	
	Q151C1230TF2	六角头螺栓	Screw	12	
	Q40312	弹簧垫圈	Spring washer	16	

9	190003989290	碗形堵塞	Core plug	1	
11	Q43705	轴用钢丝挡圈	Snap clip	1	
12	WG9112330016	销	Pin	1	
12a	WG9231330808	销	Pin	1	
12b	WG9231330809	销	Pin	1	
13	1680M 320015	O型垫圈	O-ring	1	
14	WG9014330125	操纵杆总成	Operating Lever ass.	1	
15	WG81500010163	螺塞	Plug	1	
16	Q1200850F3	双头螺柱	Stud	1	
17	WG61000060084	间隔衬套	Spacer bush	1	
18	Q40108	平垫圈	Washer	1	
19	Q33208	2型全金属六角锁紧螺母	Nut	1	

4.05 后桥桥壳/ Rear Axle Housing

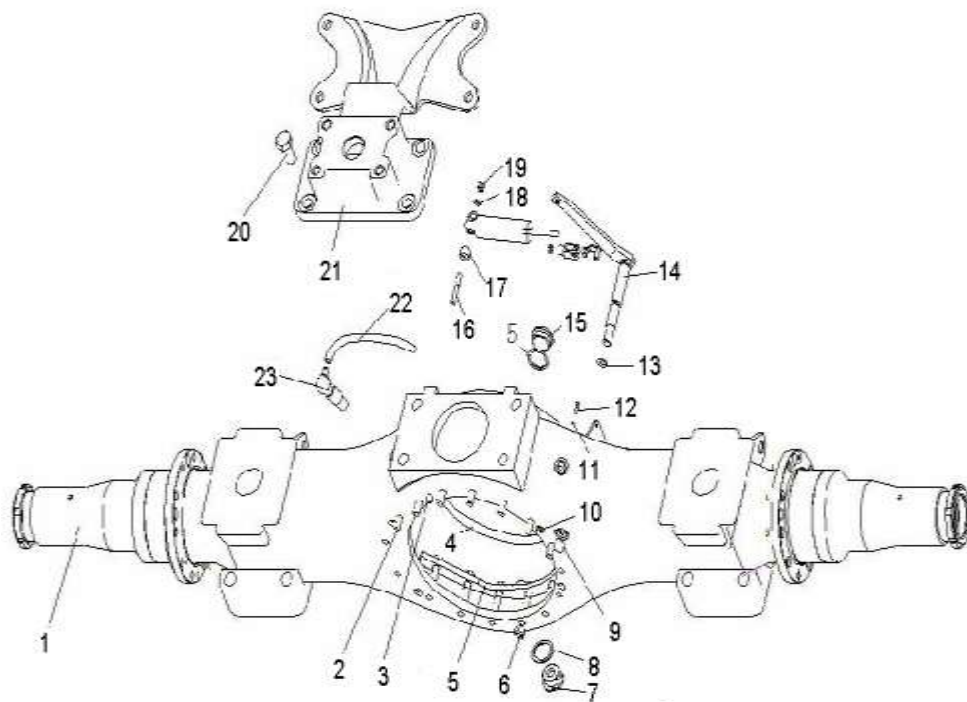

4.05 后桥桥壳/ Rear Axle Housing

序号	零部件图号	名称	Part Name	数量	备注
No.	Part No.			Qty	Remark
20	Q151B2045TF2	六角头螺栓	Screw	7	
21	WG9231340943	气室支架 (后桥)	Bracket of chamber	1	
22	WG9231330106	橡胶软管	Hose	1	
23	WG9231330105	通气塞	Breathing plug	1	
	Q151C1230TF2	六角头螺栓	Screw	12	
	Q40312	弹簧垫圈	Spring washer	16	
	WG2297Y4835	铭牌	Nameplate	1	
	190003904529	标牌铆钉--铆钉2.5*6	Rivet	2	

4.06 三段式铸造后桥轮毂及制动器/Hub and Brake of Driving Axle

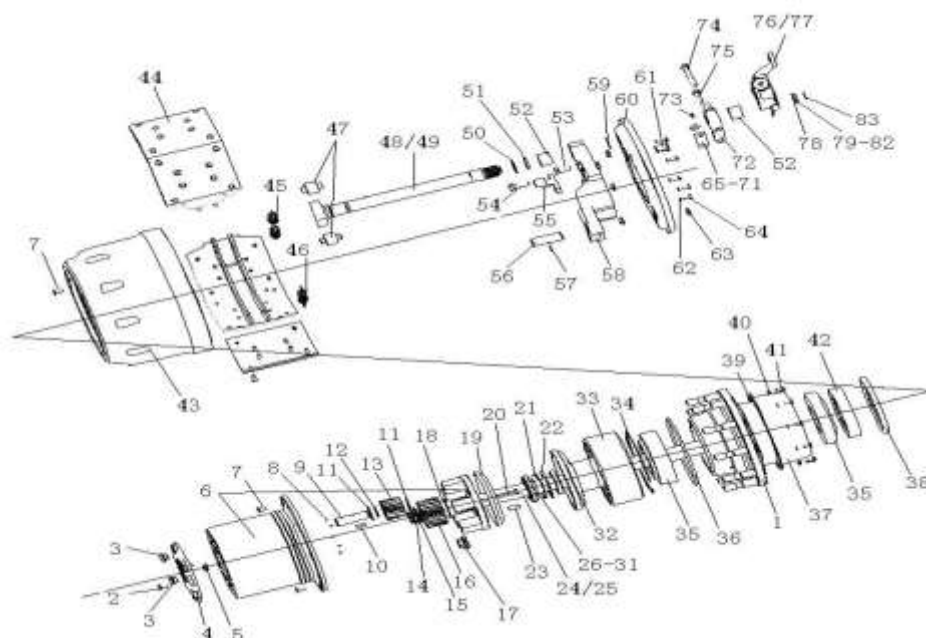

4.06 三段式铸造后桥轮毂及制动器/Hub and Brake of Driving Axle

序号 No.	零部件图号 Part No.	名称	Part Name	数量 Qty	备注 Remark
1	AZ9231340310	后轮毂总成	Rear wheel hub ass.	4	
1,1	WG9231340309	后轮毂	Rear wheel hub	1	
1,2	WG9112340123	车轮螺栓(后)	Screw	10	
2	Q150B1018	六角头螺栓	Screw	40	
3	WG9231340002	圆柱头内六角螺塞总成	Plug screw	8	
4	WG9231340001	端盖	Cover	4	
5	WG9012340011	端盖顶销	Pin	4	
6	AZ9231340329	行星架总成	Planetary carrier	4	
7	Q2541025	十字槽沉头螺钉	Screw	16	
8	190003330148	钢球	Steel ball	20	
9	WG9012340004	行星轮轴	Planet pinion shaft	20	
11	WG9012340075	行星轮垫片	Shim- Planet pinion	40	
12	WG9012340077	垫圈	Washer	20	
13	WG9012340122	行星轮(Z=16)	Planet pinion	20	

14	19000393351	轴用弹性挡圈	Circlip for shaft	4	
15	WG880 410097	垫圈	Washer	4	
16	WG9012340005	太阳轮 (Z=23)	Sun gear	4	
17	WG9003884160	车轮螺母	Nut	40	
18	WG9012340076	太阳轮垫圈	Washer	4	
19	WG880420027	行星架挡油盘	Oil drip plate	4	

4.06 三段式铸造后桥轮毂及制动器/Hub and Brake of Driving Axle

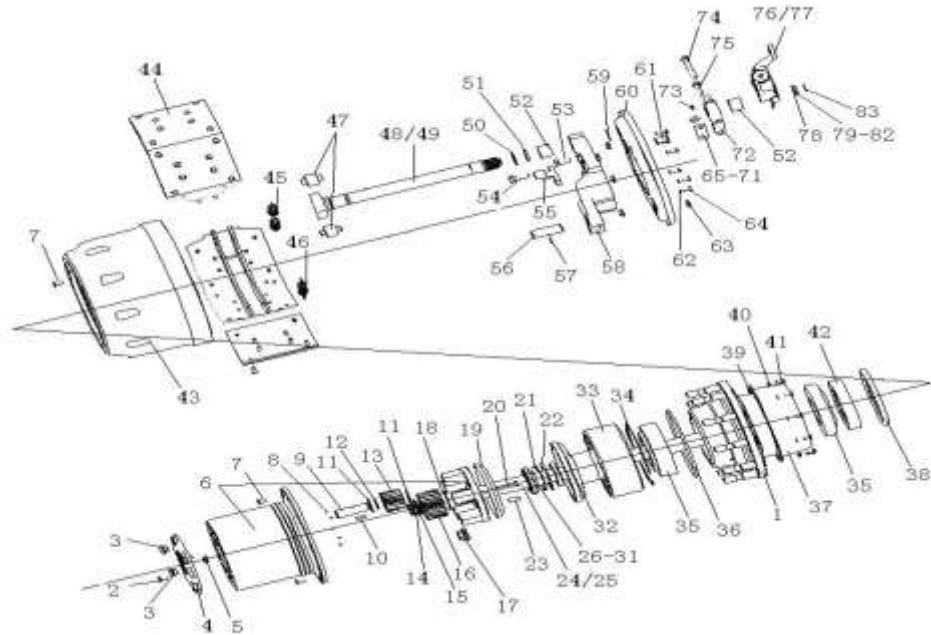

4.06 三段式铸造后桥轮毂及制动器/Hub and Brake of Driving Axle

序号	零部件图号	名称	Part Name	数量	备注
No.	Part No.			Qty	Remark
20	Q151C1295TF2	六角头螺栓	Screw	20	
21	WG680340015	止推垫圈	Thrust washer	4	
22	WG9231340034	止推垫环	Thrust washer	4	
23	190003901704	园柱销	Cylinder pin	20	
24	WG9231340223	半轴 (左)	Half shaft(left)	2	
25	WG9231340224	半轴 (右)	Half shaft(right)	2	
26	WG680340016	调整垫片(厚0.1)	Adjusting shim	2	
27	WG680340017	调整垫片(厚0.2)	Adjusting shim	2	
28	WG680340018	调整垫片(厚1.0)	Adjusting shim	2	
29	WG680340019	调整垫片(厚1.5)	Adjusting shim	2	
30	WG680340186	调整垫片(厚0.5)	Adjusting shim	2	
31	WG680340187	调整垫片(厚0.15)	Adjusting shim	2	
32	WG9112340021	齿圈支架总成	Bracket assembly of gear ri	4	
33	WG9012340121	内齿圈 (Z=57)	Ring gear	4	
34	WG880420014	轴用挡圈	Circlip for shaft	4	
35	WG9981032222	圆锥滚子轴承	Bearing	8	
36	WG9012340029	密封圈	Sealing ring	8	

37	WG9231340921	挡油罩	Oil drip pan	4	
38	WG9981340113	轴密封圈	Sealing ring	4	
39	WG9012340020	密封垫片	Sealing Shim	4	

4.06 三段式铸造后桥轮毂及制动器/Hub and Brake of Driving Axle

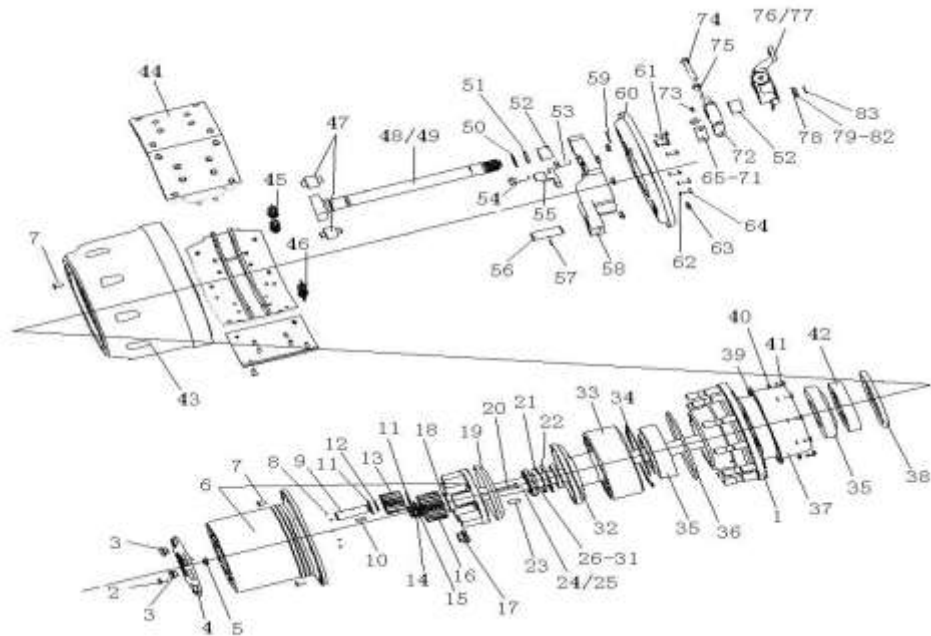

4.06 三段式铸造后桥轮毂及制动器/Hub and Brake of Driving Axle

序号 No.	零部件图号 Part No.	名称	Part Name	数量 Qty	备注 Remark
40	Q40308	弹簧垫圈	Spring washer	40	
41	Q150B0816	六角头螺栓	Screw	40	
42	WG9231340317	隔圈	Spacer ring	4	
43	WG9231342006	后制动鼓	Rear brake drum	4	
44	AZ9231342070	制动蹄带衬片总成	Brake shoe assembly	8	
44,1	WG9231342061	制动蹄	Brake shoe	1	
44,2	WG9231342068	制动摩擦片	Brake lining	2	
44,3	WG9231340068	铆钉	Rivet	28	
45	WG9981341006	回位弹簧	Rebound spring	4	
46	WG9112340049	回位弹簧	Rebound spring	8	
47	WG9000340027	滚轮	Roller	8	
48	WG9231340226	制动凸轮轴(左)	Brake camshaft (left)	2	
49	WG9231340227	制动凸轮轴(右)	Brake camshaft (right)	2	
50	WG880440010	附加垫片	Shim	8	
51	WG880340023	O形密封圈	O-ring	4	
52	WG9100340017	复合衬套	Bush	8	
53	Q151B1635TF2	六角头螺栓	Screw	32	
54	Q151B1645TF2	六角头螺栓	Screw	8	
55	AZ9231340957	ABS传感器支架	Bracket for ABS sensor	4	
56	199000340064	支销	Pin	8	

4.06 三段式铸造后桥轮毂及制动器/Hub and Brake of Driving Axle

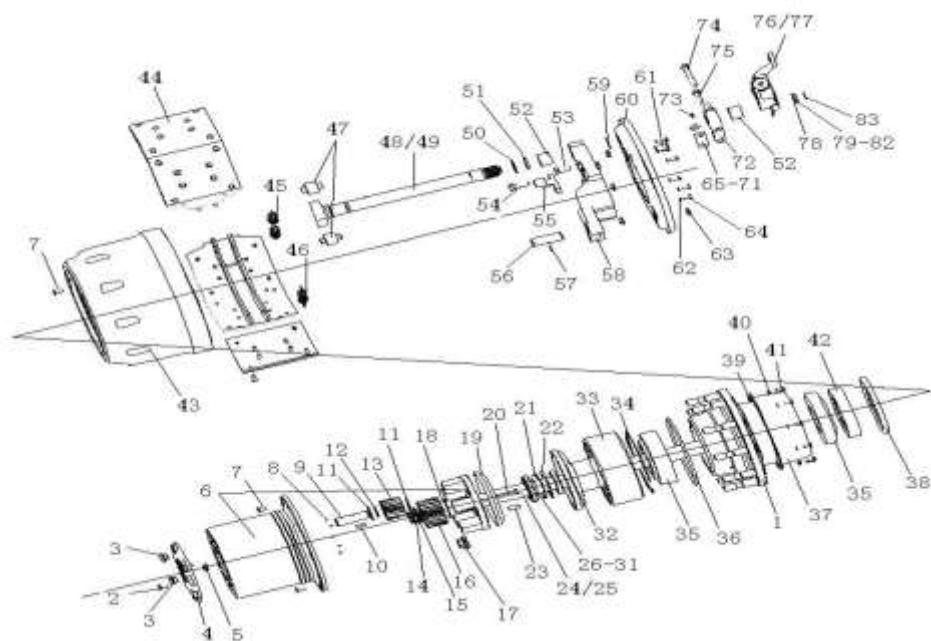

4.06 三段式铸造后桥轮毂及制动器/Hub and Brake of Driving Axle

序号 No.	零部件图号 Part No.	名称	Part Name	数量 Qty	备注 Remark
57	Q5280624	弹性园柱销	Elastic pin	8	
58	AZ9231340562	制动底板	Brake base plate	4	
59	190003933300	轴用弹性挡圈	Circlip for shaft	4	
60	AZ9231342008	制动器防尘罩	Brake dustproof cover	4	
61	WG9112340010	ABS传感器输出保护套	Protective sleeve for sensor	4	
62	Q40308	弹簧垫圈	Spring washer	24	
63	WG880340037	密封圈	Sealing ring	16	
64	Q150B0816	六角头螺栓	Screw	24	
65	WG880340031	调整垫片(厚0.1)	Adjusting shim	2	
66	WG880340032	调整垫片(厚0.15)	Adjusting shim	2	
67	WG880340033	调整垫片(厚0.4)	Adjusting shim	2	
68	WG880340034	调整垫片(厚1.0)	Adjusting shim	2	
69	WG3809470031	调整垫片	Adjusting shim	2	
70	WG3809470032	调整垫片	Adjusting shim	2	
71	WG3809470033	调整垫片	Adjusting shim	2	
72	199014340041	凸轮轴支架	Bracket of camshaft	4	
73	AZ9003963030	滑脂嘴总成	Grease nozzle	4	
73.1	190003963112	米制锥螺纹滑脂嘴	Grease nozzle	1	
73.2	AZ9003963010	滑脂嘴帽	Cap of the grease nozzle	1	
74	Q151B1490	六角头螺栓	Screw	4	

4.06 三段式铸造后桥轮毂及制动器/Hub and Brake of Driving Axle

